

Worksheet - 03 - Resistors

Name:

1. What is the potential difference across an ideal ammeter.
2. What is the current through an ideal volt meter?
3. Write down the Ohm's law formula

Calculate the value of R_1 .

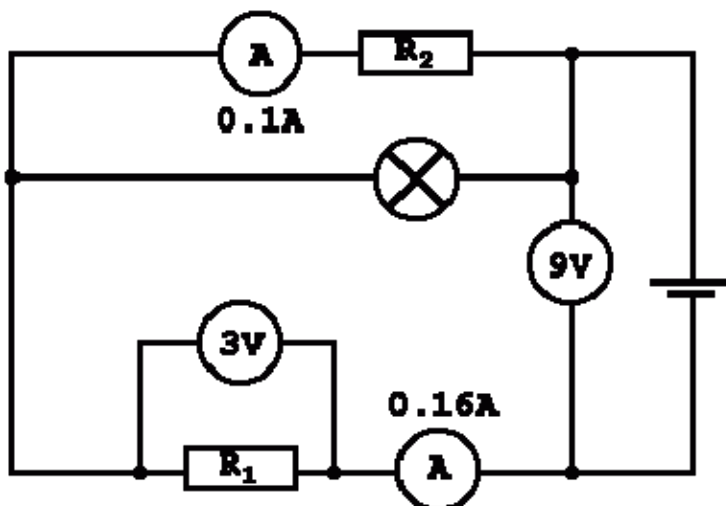

4. In this circuit, what is the current flowing through the battery. Give your answer in milliamps.

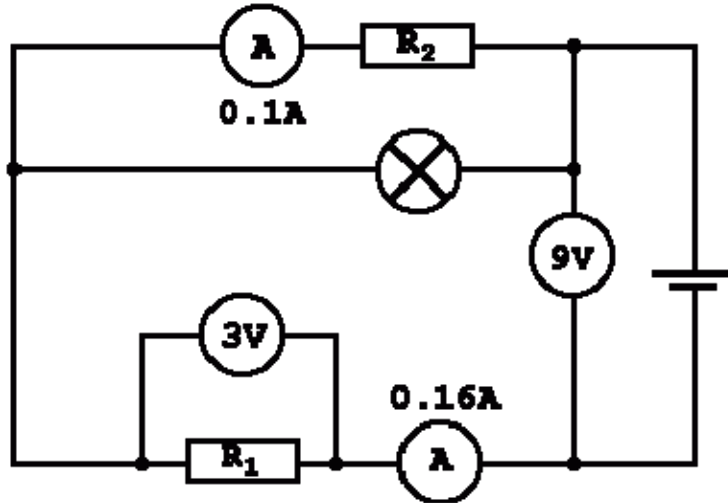

5. What is the battery voltage in the circuit above?
6. In the circuit above, what is the current flowing through R₁?
7. In the circuit above, what is the current through the lamp?
8. In the circuit above, what is the potential difference across R₁?
9. In the circuit above, what is the potential difference across R₂?
10. In the circuit above, what is the potential difference across the lamp?

11. In the circuit above, what is the resistance of the lamp?

12. What is the name of the circuit below?

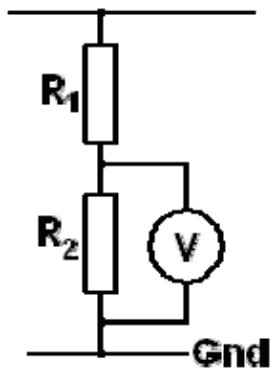

13. In the circuit above, if $R_1 = 40$ Ohms, $R_2 = 22$ Ohms and the Supply Voltage = 7 Volts, calculate the potential difference across R_2 .

14. In the circuit below, if $V = 9$ Volts, $A_1 = 4$ amps and $A_2 = 1$ amp, calculate R_2 .

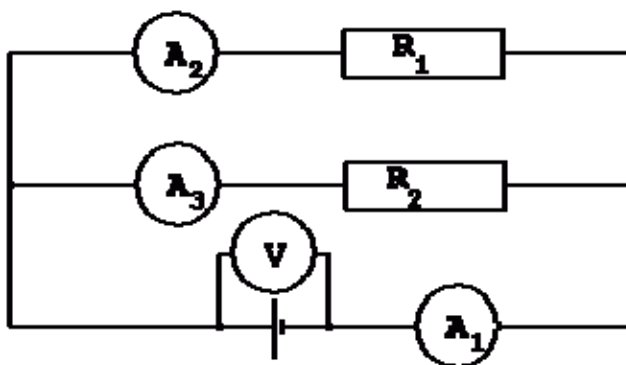

15. Write down the resistors in parallel formula.

If a 37 Ohm resistor is in parallel with a 39 Ohm resistor, calculate the overall resistance.

If three resistors are in parallel and their values are 12, 12 and 6 Ohms, calculate the combined resistance.

16. Use the graph below to estimate the resistance when the temperature is 25C.

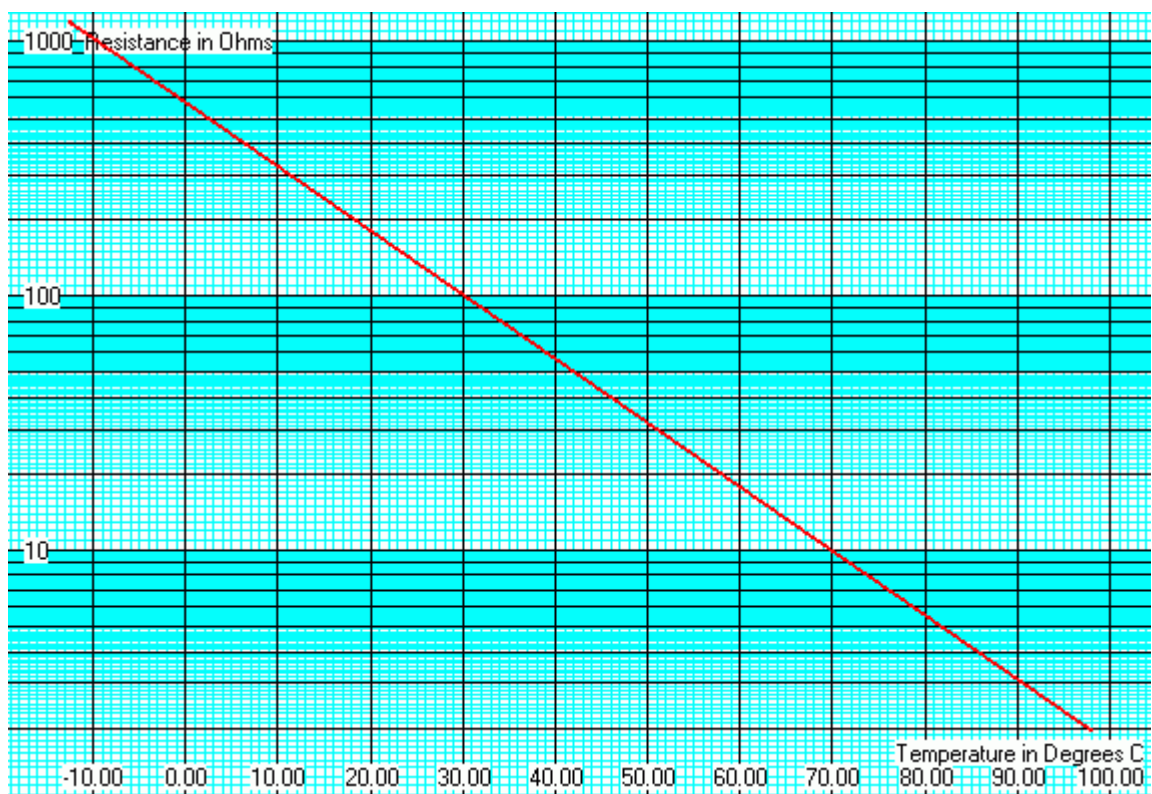

17. Use the graph above to estimate the temperature when the resistance is 100 Ohms?

18. Use the graph above to find the thermistor resistance at 90C?

19. Use the graph above to find the temperature when the resistance is 590 Ohms

20. The oscilloscope below is set to one volt per division. What is the peak voltage shown on the trace below?

