

Practical Task

This circuit can be used to test the behaviour of any low voltage / low current diode. These include typical silicon diodes such as the 1N4001, LEDs and Zener diodes. The activity below shows an LED.

Build this circuit and measure and record the potential difference across the diode and the current through it. Repeat these measurements for the full range of movement of the potentiometer. Plot a graph of your results. Plot your graph as you go and get sufficient readings before you dismantle your circuit.

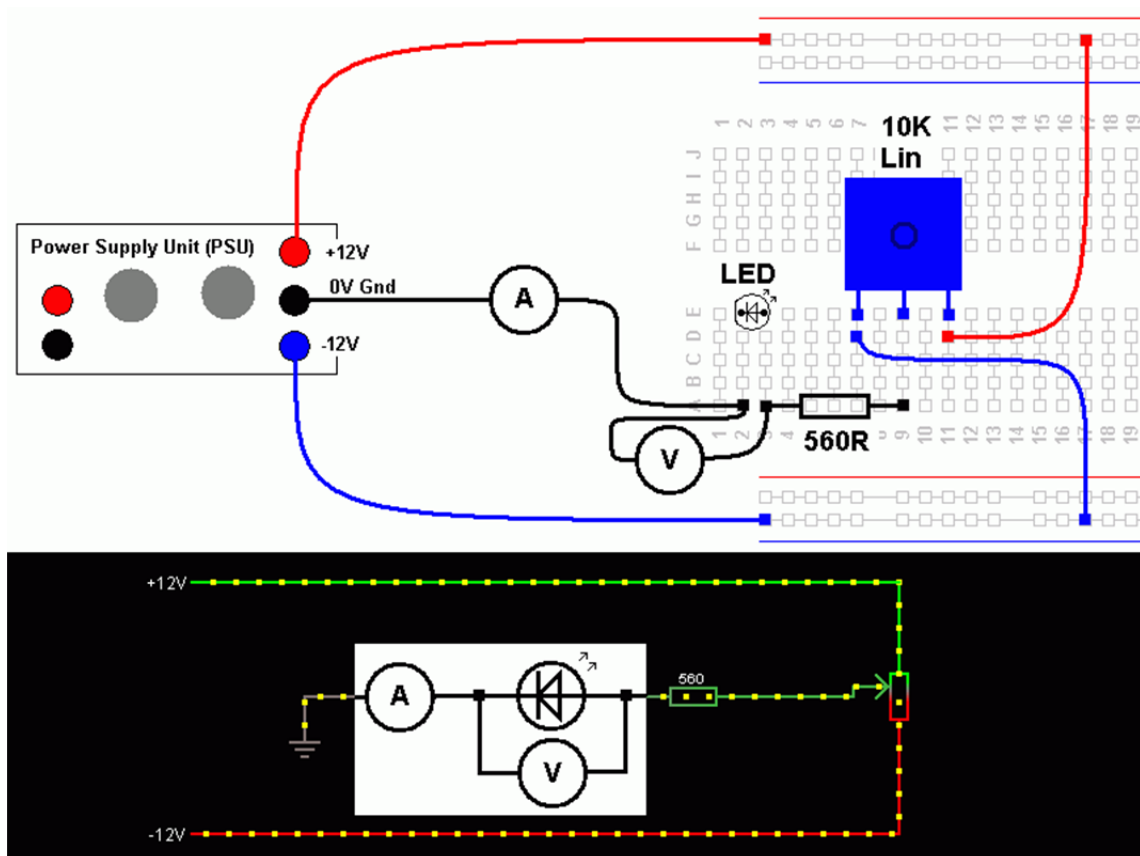

Your tasks ...

- Take all the necessary measurements - do this **before you dismantle** your circuit.
- Plot a graph showing the current through a diode as the potential difference across it is altered.
- Take additional measurements to fill gaps in your graph - especially where the graph is curved.

Make sure there are **no gaps in your graph** where extra measurements should have been taken.