

Worksheet - 04 - Diodes

Name:

1. What is the approximate potential difference across a forward biased silicon diode when a few milliamps are flowing?
2. What is the approximate potential difference across a forward biased germanium diode when a few milliamps are flowing?
3. What is the approximate potential difference across a forward biased LED when about 10 milliamps are flowing?
4. The LED below can carry 10mA safely. If the power supply voltage is 9V
 - a) calculate a suitable value for the series resistor
 - b) what E24 value would you select?

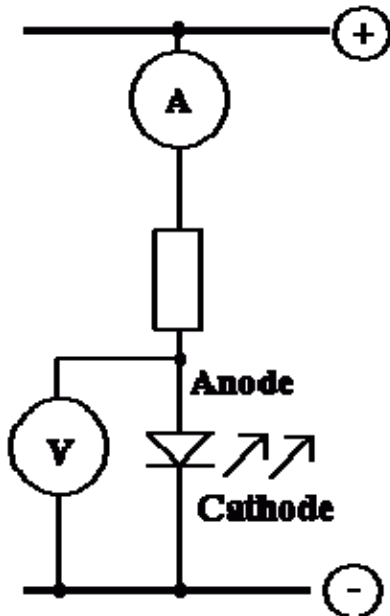

5. The LED in (Q4) carries 10mA. If the power supply voltage is 9V, calculate the power dissipated in the LED. Give your answer in milliwatts.

6. The LED in (Q4) carries 10mA. If the power supply voltage is 12V, calculate the power dissipated in the whole circuit. Give your answer in milliwatts.

7. The LED in (Q4) carries 10mA. If the power supply voltage is 12V, calculate the power dissipated in the series resistor. Give your answer in milliwatts.

8. In (Q4), to the nearest milliamp, how much current flows through the voltmeter.

9. In (Q4), to the nearest millivolt, what is the potential difference across the ammeter?

10. What type of rectifier is shown in the diagram below?

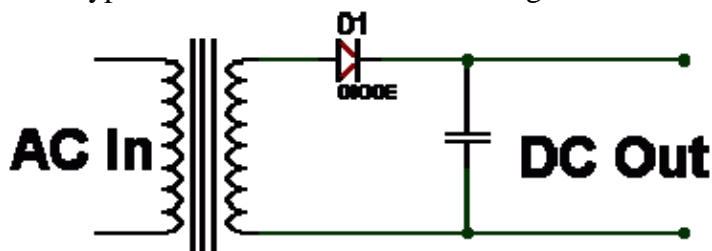

11. The transformer output is shown below. Sketch the DC voltage you would expect after the diode
 - a) without the smoothing capacitor
 - b) with a smoothing capacitor that is not big enough
 - c) with a very big smoothing capacitor

Sketch the wave shapes on top of the diagram below and label them a, b, and c.

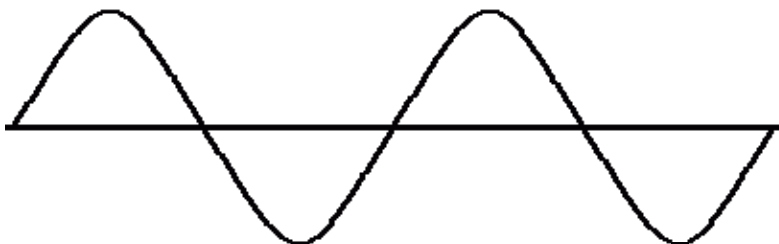

12. The zener diode in the diagram below is not the normal way round for a conducting diode. What is the correct technical term used to describe this?

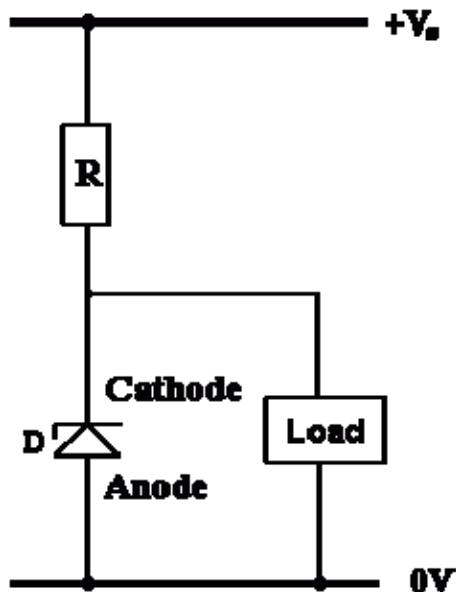

13. In the circuit in (Q12), the supply voltage is 12V and the required stabilised load voltage is 5V. If the maximum load current is 95mA, calculate in Ohms the value of R . Assume that at least 5 mA must flow through the zener diode for it to function correctly.
14. In (Q12), the supply voltage is 12V and the required load voltage is 5V. If the maximum load current is 95mA and the minimum allowed zener current is 5mA, calculate in milliwatts the heat dissipated in D when the load current is zero.
15. In (Q12), the supply voltage is 12V and the required load voltage is 5V. If the maximum load current is 95mA and the minimum allowed zener current is 5mA, calculate in milliwatts the heat dissipated in R .
16. In (Q12), the supply voltage is 12V and the required load voltage is 5V. If the maximum load current is 95mA and the minimum allowed zener current is 5mA, in Ohms, what e24 resistor value would you use for R ?